

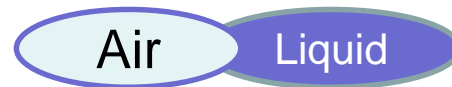

“FFNV1” series



Needle valve without multi dial. Various needle lineup!

■ Features

- Smooth and precise flow rate control is possible (about 13 rotations) by making the needle part non-rotating structure.
- Needle valve can be set according to usage conditions from a wide range of needle valve lineup.
- We have various seal materials.



■ Applications

- Machine Tools : Milling machine, NC lathe, laser processing machine etc.
- Industrial furnace : General industrial furnace, heating furnace, vacuum furnace, etc.
- Medical : Endoscope washing device, oxygen concentrator, anesthesia machine etc.
- Analysis equipment: Measurement equipment, component gas analysis, gas analyzer etc.
- Battery : Household fuel cell, secondary battery, gas engine etc.
- Water (liquid) treatment: Pure water production, pure water recycling.
- Gas generator related: Compressor, compact pressure vessel, various gas generator etc.
- Others: Oxygen capsule, gasoline measuring instrument, forklift etc.

■ Specification

Working fluid	Gas or liquid that touching parts are not corroded.	Body material	Brass	Brass (Nickel plating)
			Stainless	SUS316
Maximum working pressure Mpa[psi]	1.0 [145.04]	Materials in contact with gas	Brass	Brass, SUS316, PTFE, FKM(Standard)
			Stainless	SUS316, PTFE, FKM(Standard)
Pressure Resistance Mpa[psi]	1.5 [217.56]	Operating temperature range °C[°F]	Brass	0~60 [32~140]
			Stainless	0~120 [32~248]
Pipe port	Rc1/4	Number of rotations	13 rotations	
Comment	Tube piercing fitting specifications correspond only to stainless steel specifications. Please contact us for detailed dimensions.			



Size

Angle-type(L) standard

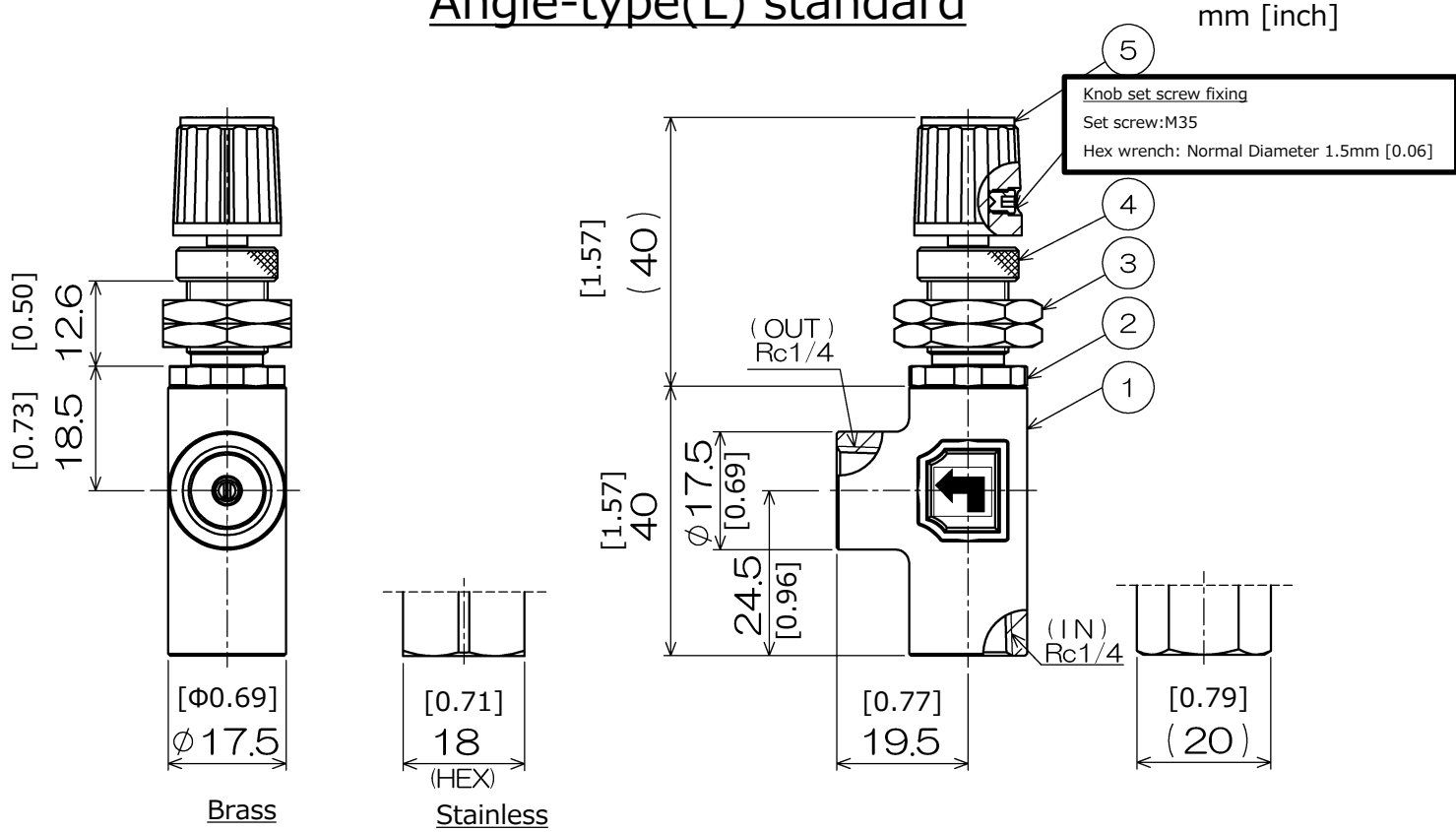

Straight-type(T) standard

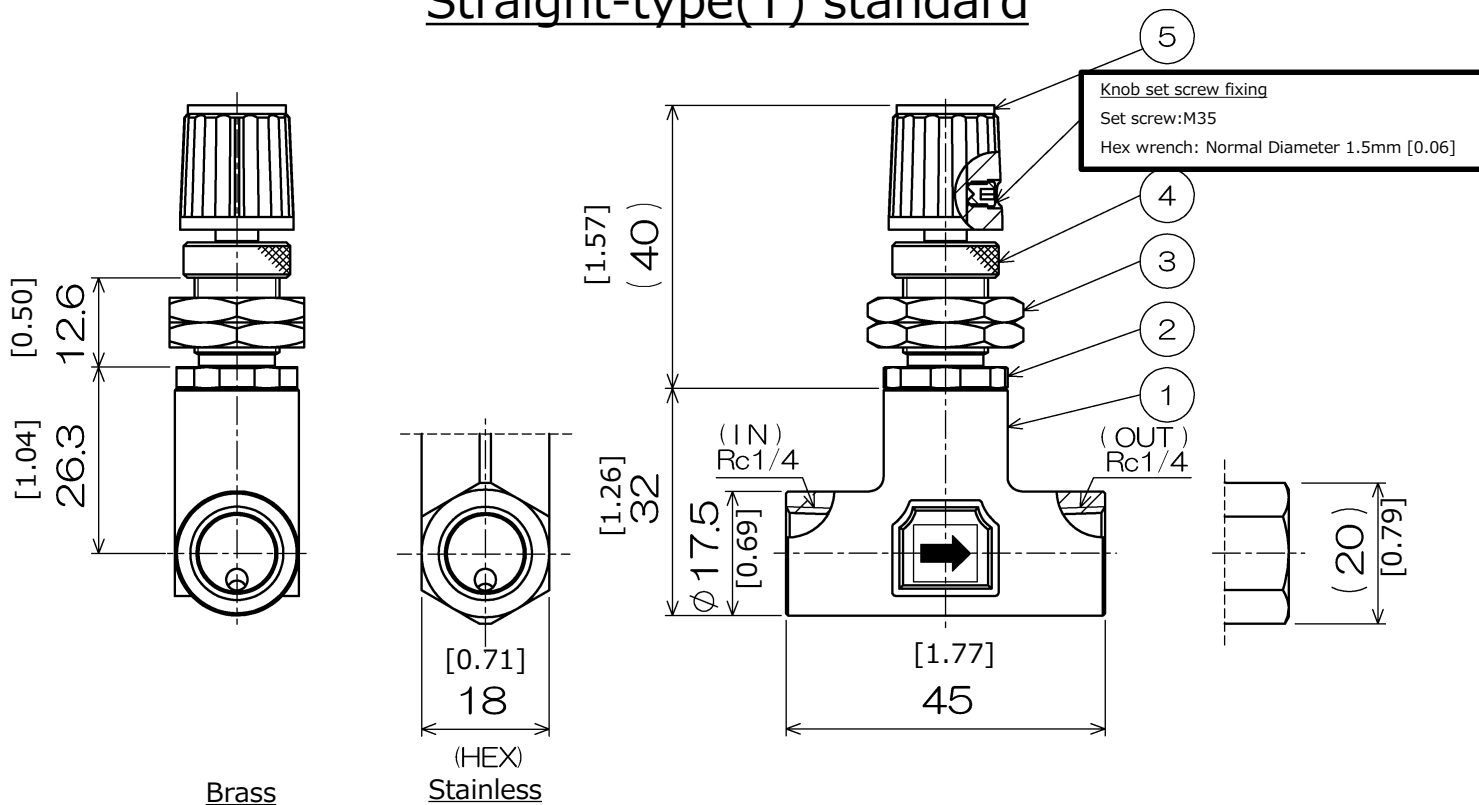



FUJIKURA COMPOSITES

Part material list

Number	Name	Material	
		Brass type	Stainless type
①	Valve body	C3771(Nickel plating)	SUS316
②	Needle body	C3604(Nickel plating)	SUS316
③	Panel nut	C3604 (Nickel plating)	
④	Cover nut	C3604 (Nickel plating)	
⑤	Knob	Nylon (Standard)	

■ Knob Dimensions

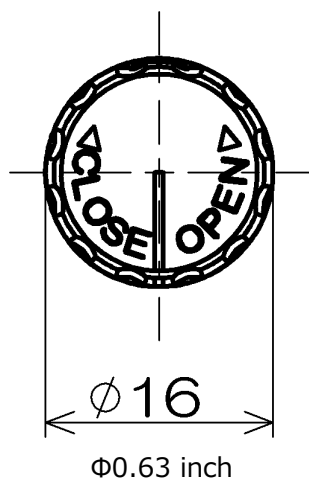

■ Panel cut Dimensions

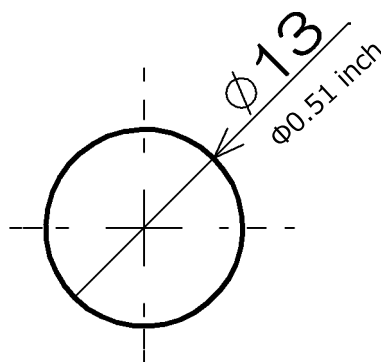

■ Flareless joint

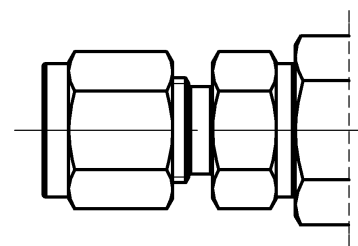

*Please ask us for dimensions.

Model designation



Model name	
FFNV1	Precision type

Body material	
B	Brass
T	Stainless

Seal material	
V	FKM (Standard)

*Please contact us for other materials.

Knob material	
None	Nylon (Standard)
A	Aluminum alloy

No oil treatment	
None	None
NO	No oil treatment

Valve type	
L	Angle type
T	Straight type

Pipe port	
2	Rc 1/4 (Standard)
T1	$\phi 1/8$ tube joint
T2	$\phi 1/4$ tube joint
TM4	$\phi 4\text{mm}[0.16\text{inch}]$ tube joint
TM6	$\phi 6\text{mm}[0.24\text{inch}]$ tube joint

*The material of the tube fitting is SUS only.

Needle No.			
Needle No	Maximum CV value (When fully open)	Needle No	Maximum CV value (When fully open)
N1	0.00021	N6	0.031
N2	0.0012	N7	0.04
N3	0.004	N8	0.12
N4	0.006	N9	0.15
N5	0.016	N10	0.25

*CV values may differ depending on usage conditions. Please use as a reference value.



FUJIKURA COMPOSITES

■ Characteristic

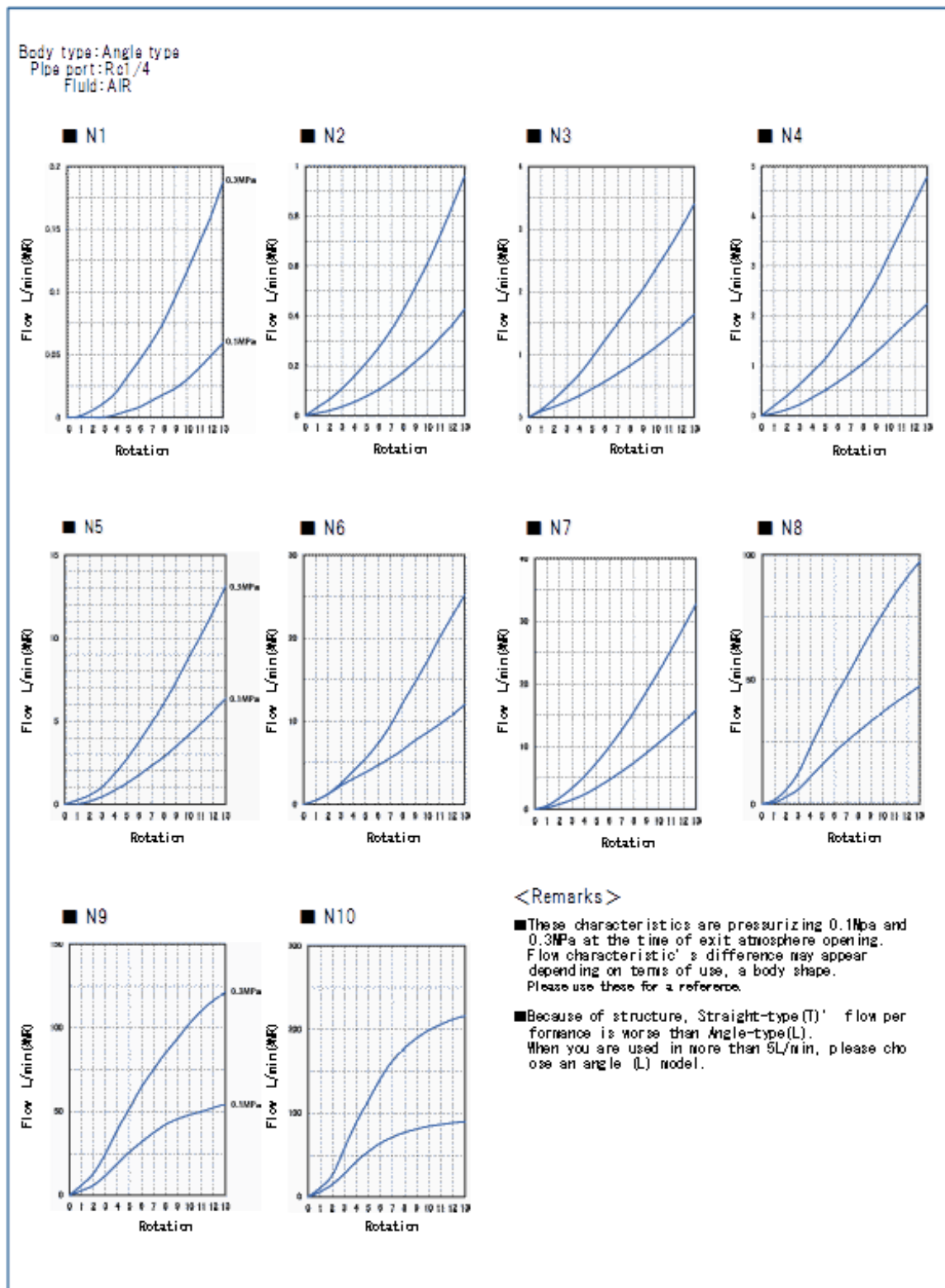

Contact us

Control Equipment

Head office: TOC Ariake East Tower 10F, 3-5-7 Ariake, Koto-ku, Tokyo, Japan 135-0063

TEL +81-3-3527-8573

E-mail: seigyotoiawase.en@fc.fujikura.co.jp

URL: <https://www.fujikura-control.com/>